

Direct 9 Series

ARINC 801 Optical Transceiver,
Fast or GbE, 1x/2x/4x FC & sFPDP
Applications, Multimode, 850nm

Duplex Optical Transceiver Unit

FEATURES

- Compliant with Fast or Gigabit Ethernet - IEEE-802.3:2005 and 1x/2x/4x FC - ANSI Fibre Channel FC-PI-2, FC-PI and FC-PH-2
- Optical fiber link distances up to 550 Meters (50/125µ 500MHz*Km MMF)
- Maximum optical channel bit error rate less than 1×10^{-12}
- Operating temperature range from -40°C to +85°C
- Shock and vibration resistant per RTCA / D0-160E
- Electroless nickel plating meets stringent EMI / RFI performance specifications
- D-Subminiature housings are strong, durable, corrosion resistant and light weight
- ARINC 801 compliant optical fiber connector interface
- DB-9 threaded mating connectors provide secure interface conditions in high vibration environments

APPLICATIONS

Direct 9 series printed circuit board mounted optical transceivers enable high speed network communications over long distances in harsh environments.

- Fast or Gigabit Ethernet switches and peripherals
- Fibre Channel switches and peripherals
- sFPDP data links
- Video displays

The size 9 D-Subminiature shell provides a rugged optical interface that is compliant with ARINC 801.

The multimode optical fiber interface supports applications where copper cable link distance, bandwidth, weight or bulk make the use of twisted pair, twinax or quadax copper conductors unacceptable.



One TX & One RX Channel Operating from 125Mbps to 4.25Gbps

DESCRIPTION

Direct 9 series D-Subminiature optical fiber transceivers consist of optoelectronic transmitter and receiver functions integrated into a printed circuit board mounted D-Subminiature / ARINC 801 compliant receptacle connector. The optical transmitters are 850nm VCSEL lasers. The transmitter input lines are driven with differential CML signals applied to the transmitter (TX+ and TX-) lines. Dual loop, temperature compensated, VCSEL drivers convert the transmitter input signals to suitable VCSEL bias and modulation currents. Outputs from the receivers consist of differential CML data signals on the receiver (RX+ and RX-) lines. A CMOS signal is generated on the LOS line upon loss of a valid incoming optical signal. The receiver data lines are squelched upon LOS assertion, preventing errant data generation when an invalid incoming optical signal is presented to the transceiver.

The optical mating interface to the Direct 9 series D-Subminiature optical fiber transceivers is a DB-9 fiber optic cable plug with ARINC 801 contacts. The electrical interface to the Direct 9 series D-Subminiature optical transceivers is a solder pin field with the same PCB footprint as existing electrical right angle 9 position D-Subminiature connectors.

Direct 9 series D-Subminiature optical fiber transceivers are vibration isolated, environmentally hardened components designed for use in harsh environment applications.

ORDERING INFORMATION

Application	Part Number
125Mbps to 2.125Gbps	P24D-2S1D-EF
2.5Gbps to 3.2Gbps	P24D-2S1E-EF
3.2Gbps to 4.25Gbps	P24D-2S1G-EF

Single Port Direct 9 Series D-Subminiature / ARINC 801 Optical Transceiver,
Fast or GbE, 1x/2x/4xFC or sFPDP Applications, Multimode, 850nm VCSELs

ABSOLUTE MAXIMUM RATINGS

Absolute maximum limits mean that no catastrophic damage will occur if the product is subjected to these ratings for short periods, provided each limiting parameter is in isolation and all other parameters have values within the performance specification. It should not be assumed that limiting values of more than one parameter can be applied to the product at the same time.

Parameter	Symbol	Minimum	Typical	Maximum	Unit
Storage Temperature	T_s	-55		+100	°C
Supply Voltage	V_{CC}	-0.5		+4.5	V
TX_DIS Input Voltage	V_I	-0.5		$V_{CC} + 0.5$	V

RECOMMENDED OPERATING CONDITIONS

Parameter	Symbol	Minimum	Typical	Maximum	Unit
Operating Temperature	T_A	-40		+85	°C
Power Supply Voltage	V_{CC}	+3.135		+3.465	V
Power Supply Noise (p-p)	N_P			200	mV
TX Differential Input Voltage (p-p)	V_D	0.25		2.2	V

ENVIRONMENTAL OPERATING CONDITIONS

Requirement	Feature	Condition	Notes
RTCA / D0-160E	ESD	HBM	2200V
RTCA / D0-160E	Vibration	3.8g ² /Hz	43G rms
RTCA / D0-160E	Shock	40.0g	6-9mS
RTCA / D0-160E	Flame Resistance		30 Seconds
RTCA / D0-160E	Damp Heat	10 Cycles	24 Hours
ARINC 801	Mating Durability	500 Cycles	<0.5dB Change
FDA / CDRH / IEC-825-1	Eye Safety	Class 1	No Safety Interlocks Required

MATERIALS

Item	Detail	Notes
D-Subminiature Shell	Nickel Plated Steel	
Solder Pins	Brass	
Solder Pin Plating	Gold over Nickel	
Insert	Thermoplastic	
Shield	Nickel Plated Steel	
Alignment Sleeves	Composite Polymer	
Printed Circuits	Polyimide / FR-4	

Single Port Direct 9 Series D-Subminiature / ARINC 801 Optical Transceiver,
Fast or GbE, 1x/2x/4xFC or sFPDP Applications, Multimode, 850nm VCSELs

OPTICAL TRANSMITTERS T_A = Operating Temperature Range, V_{CC} = 3.135V to 3.465V

Parameter	Symbol	Minimum	Typical	Maximum	Unit
Optical Output Power (BER<10 ⁻¹²)	P_o	-6.5		-1.0	dBm
Optical Output Wavelength	λ_{OUT}	830	850	860	nM
Spectral Width	$\Delta\lambda_{RMS}$			0.85	nM
Extinction Ratio	ER		9.0		dB
Optical Rise, Fall Time (20% to 80%)	$t_{R,F}$			80	pS

OPTICAL RECEIVERS T_A = Operating Temperature Range, V_{CC} = 3.135V to 3.465V

Parameter	Symbol	Minimum	Typical	Maximum	Unit
Optical Sensitivity (BER<10 ⁻¹² , ER=9.0) P24x-xS1D-xx @ 125Mbps to 1.25Gbps P24x-xS1D-xx @ 2.125Gbps P24x-xS1E-xx @ 2.5Gbps to 3.19Gbps P24x-xS1G-xx @ 3.2Gbps to 4.25Gbps	P_i	-17.0 -15.0 -15.0 -14.0		0.0	dBm
Optical Wavelength	λ_{IN}	830		860	nM

POWER SUPPLY CURRENT T_A = Operating Temperature Range, V_{CC} = 3.135V to 3.465V

Parameter	Symbol	Minimum	Typical	Maximum	Unit
Supply Current per Port	I_{CCT}		175	250	mA

OPTICAL LINK DISTANCES

Protocol	62.5/125 μ 200MHz*Km	50/125 μ 500MHz*Km
4xFibre Channel - ANSI X3.297 FC-PI-2	75M	150M
2xFibre Channel - ANSI X3.297 FC-PI	150M	300M
Gigabit Ethernet - IEEE-802.3:2005	275M	550M
1xFibre Channel - ANSI X3.297 FC-PH-2	300M	500M

Single Port Direct 9 Series D-Subminiature / ARINC 801 Optical Transceiver,
Fast or GbE, 1x/2x/4xFC or sFPDP Applications, Multimode, 850nm VCSELs

OUTLINE DRAWING

Dimensions are shown as: inches (mm)

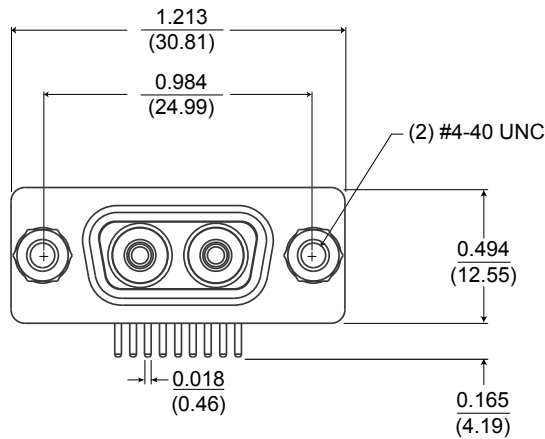

**Recommended PCB Layout
Top View - Component Side**

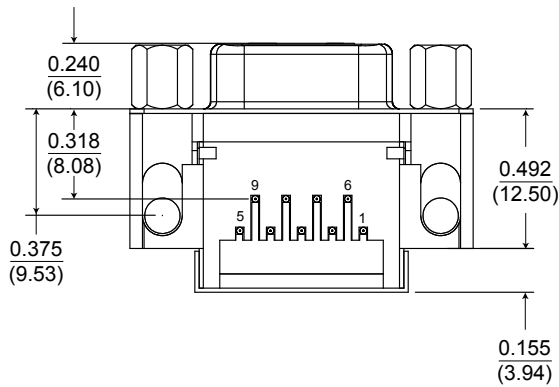
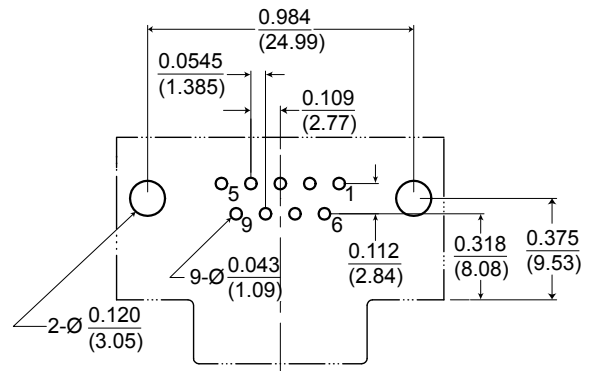

Aqueous washing is permitted with the protective covers in place.

If necessary, after washing, clean the optical barrels with lint free swabs and Isopropyl alcohol

The transceivers are conformally coated but after aqueous washing the units should be baked @ 85°C for 1.0 hour to eliminate any retained moisture.

Single Port Direct 9 Series D-Subminiature / ARINC 801 Optical Transceiver,
Fast or GbE, 1x/2x/4xFC or sFPDP Applications, Multimode, 850nm VCSELs

ELECTRICAL PIN ASSIGNMENTS

D-Subminiature Shell Size 09

Pin Number	Symbol	Description	Logic Family
1	RX-	Receiver Data - Output	CML
2	RX+	Receiver Data - Output	CML
3	GND	Ground	N/A
4	TX-	Transmitter Data - Input	CML Internal 100Ω differential termination
5	TX+	Transmitter Data - Input	CML Internal 100Ω differential termination
6	V _{cc}	Power Supply	N/A
7	LOS	Loss of Signal Indicator - Output Satisfactory Optical Input: Low Unsatisfactory Optical Input: Open	Open Drain CMOS
8	TX Dis	Transmit Disable - Input Logic 1: Disable Optical Output Logic 0: Enable Optical Output	CMOS Internal 4.7KΩ to 10.0KΩ pullup / pulldown
9	GND	Ground	N/A

INSERT ARRANGEMENT

D-Subminiature Shell Size 09

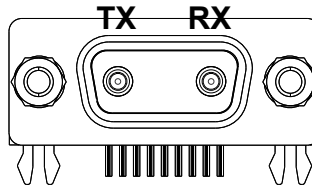

Front face of the
transceiver socket
insert shown!

Mating cable plug
interface opposite.

APPLICATION SCHEMATIC

For Xilinx Rocket I/O Interfaces

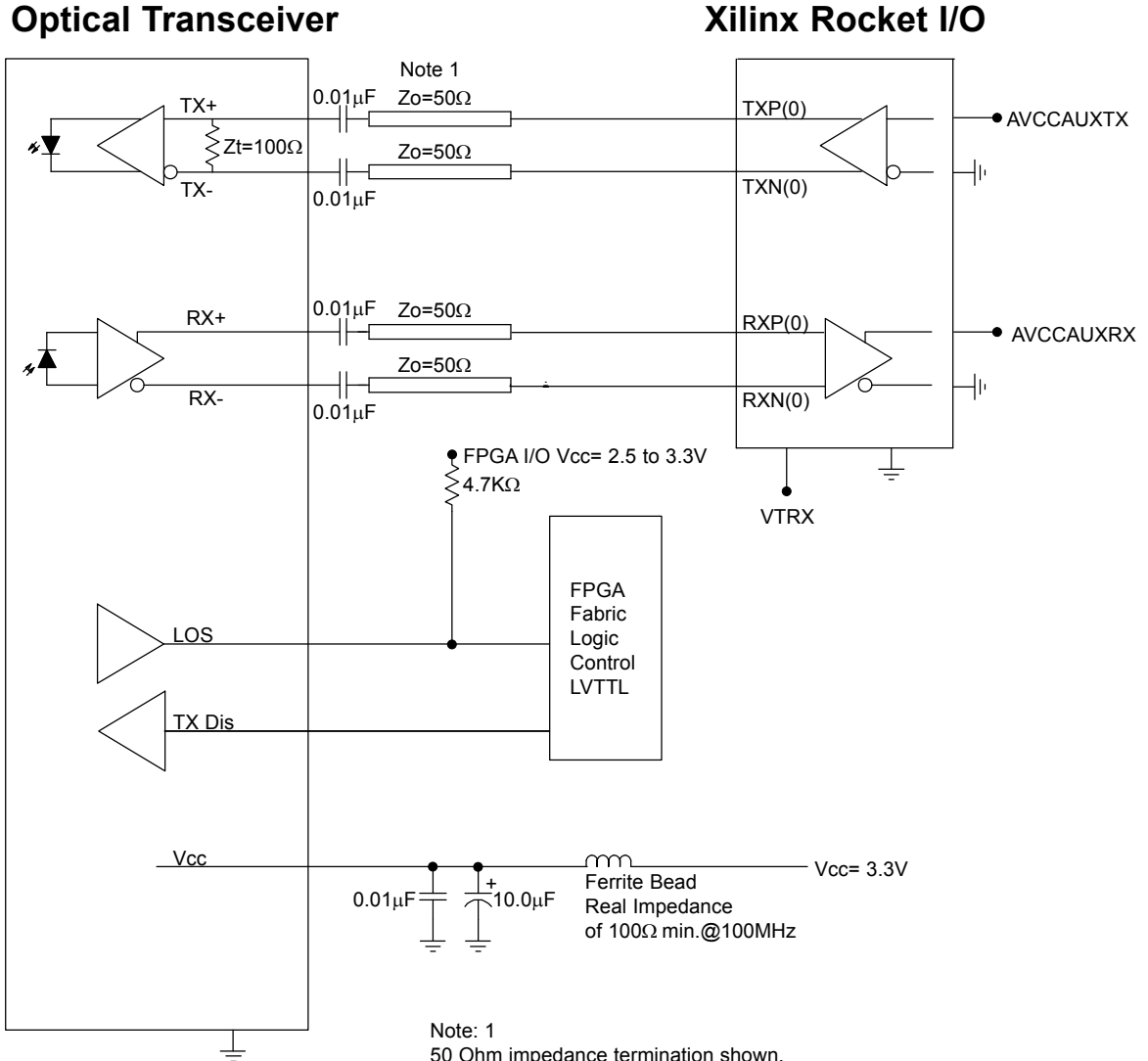

Typical application schematic shown
For alternate applications or termination
techniques, please consult the Factory

Note: 1
50 Ohm impedance termination shown.
For alternate impedance requirements,
please consult the Factory.

Single Port Direct 9 Series D-Subminiature / ARINC 801 Optical Transceiver,
Fast or GbE, 1x/2x/4xFC or sFPDP Applications, Multimode, 850nm VCSELs

APPENDIX A1

DIRECT 9 FIBER OPTIC CABLE PLUG / ARINC 801 PIN TERMINI

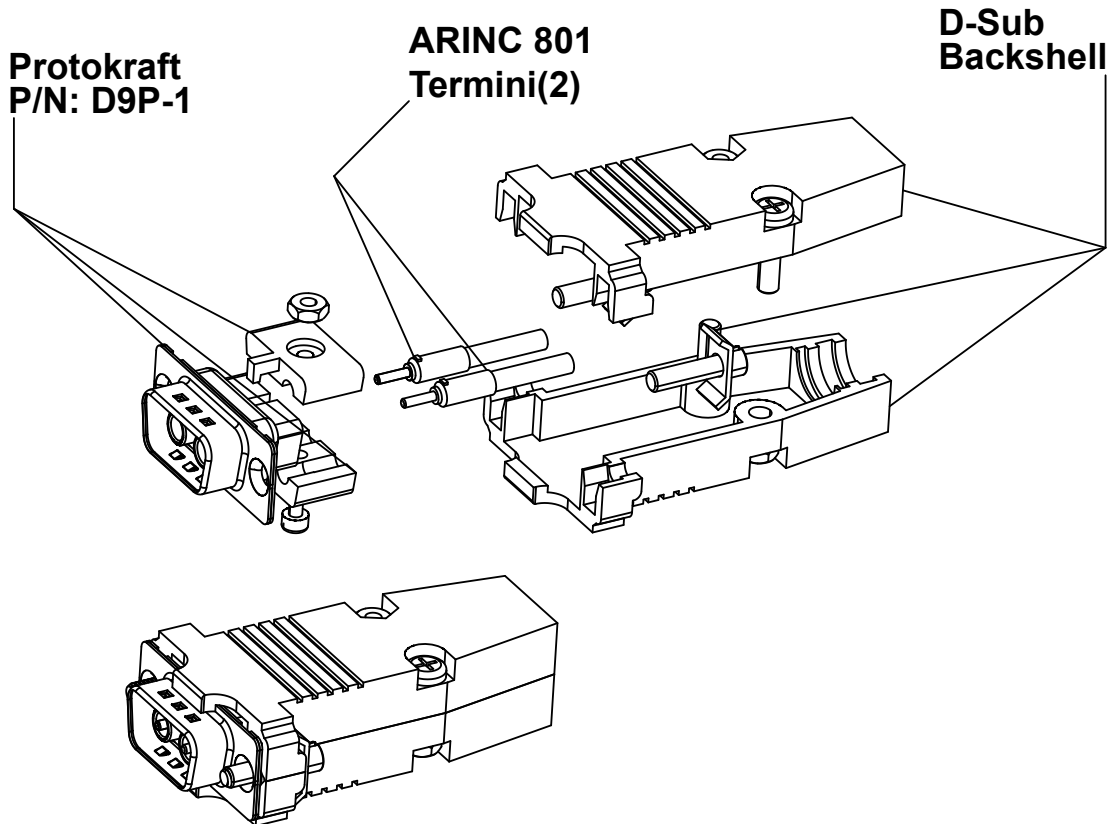

Single Port Direct 9 Series D-Subminiature / ARINC 801 Optical Transceiver,
Fast or GbE, 1x/2x/4xFC or sFPDP Applications, Multimode, 850nm VCSELs

APPENDIX A2

Direct 9 Fiber Optic D-Subminiature Cable Plug Insert

Dimensions are shown as: inches [mm]

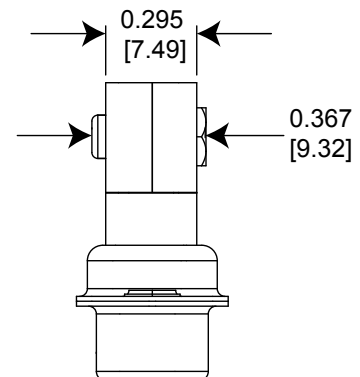
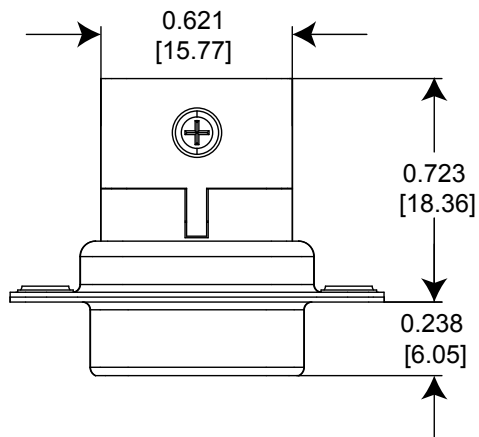
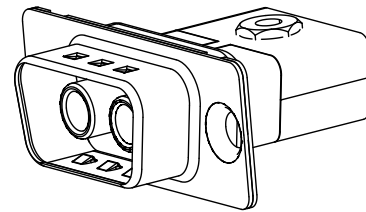
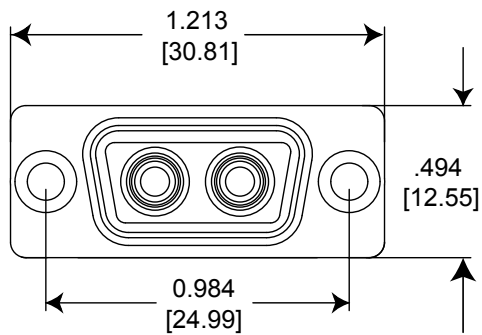

Protokraft Direct 9 Fiber Optic Cable Plug Part Number: D9P-1

See Appendix A3 for test cable options

Single Port Direct 9 Series D-Subminiature / ARINC 801 Optical Transceiver,
Fast or GbE, 1x/2x/4xFC or sFPDP Applications, Multimode, 850nm VCSELs

APPENDIX A3

Direct 9 Fiber Optic D-Subminiature Test Cable Options

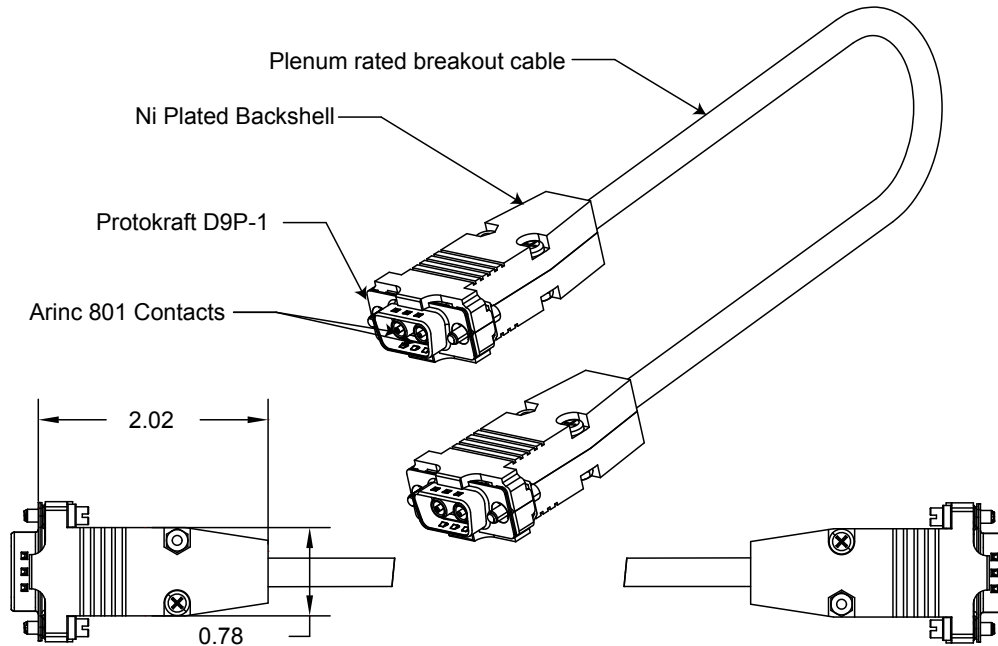

P24C-0121 -1 Shown



P24C-XX XX X X- X

- 01-99 Meters
- 1 = 50µm
- 2 = 62.5µm
- 1 = D9P-1 STRAIGHT
- 2 = D9P-1 RIGHT ANGLE
- 1 = D9P-1 STRAIGHT
- 2 = D9P-1 RIGHT ANGLE
- 3 = ST
- 4 = LC
- 5 = FC



192 Bob Fitz Road, Johnson City, TN 37615
salesmp@moog.com
moogprotokraft.com