

Lightning Series

Mil-Dtl-38999 Fiber Optic Transceiver,
RS-485 DC to 1.0MHz Applications,
Multimode, 850nm

Quad Port, Jam-Nut Receptacle

FEATURES

- Suitable for RS-485 datalinks at data rates from DC to 1.0MHz
- Optical fiber link distances up to 2.0 Kilometers
- Operating temperature range from -40°C to +85°C
- Shock, vibration and immersion resistant per Mil-Std-810
- Olive drab cadmium over electroless nickel shielding meets stringent EMI / RFI performance requirements
- Mil-T-29504 compliant optical fiber interface
- Connector insert configuration conforms to Mil-Std-1560

APPLICATIONS

Lightning series bulkhead mounted optical transceivers enable high speed communications links over long distances in harsh environments.

The Mil-Dtl-38999, Series III aluminum shell provides a sealed optical interface that is water-tight to Mil-Std-810 / IP67 / NEMA-4x when mated.

The multimode optical fiber interface supports applications where copper cable link distance, bandwidth limitations, weight or bulk make the use of twisted pair, coax, twinax or quadax copper conductors unacceptable.

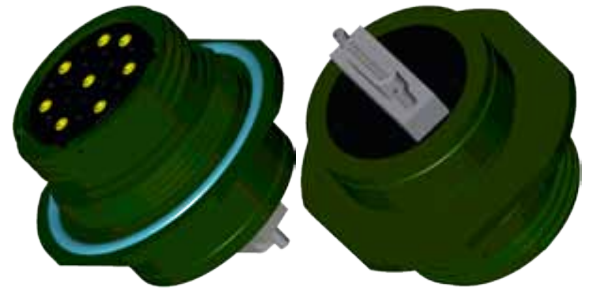

Four TX & Four RX Channels Operating from DC to 1.0MHz

DESCRIPTION

Lightning series optical fiber transceivers consist of optoelectronic transmitter and receiver functions integrated into a bulkhead mounted Mil-Dtl-38999 series III receptacle connector. The optical transmitters operate at 850nm. The transmitter input lines are driven with differential RS-485 signals applied to the transmitter lines. The optical receivers consist of PIN and preamplifier assemblies and limiting post-amplifiers. Outputs from the receivers consist of differential RS-485 data signals on the receiver lines.

The electrical interface to the Lightning series optical transceivers is a Mil-Std-83513 Micro D-Subminiature connector enabling connection to a customer supplied cable assembly.

Lightning series optical fiber transceivers are vibration isolated, environmentally hardened components ready for use in harsh environment applications.

- Sealed against liquid and solid contaminants
- Shock and vibration resistant

ORDERING INFORMATION

Application	Product Number
RS-485, DC to 1.0MHz	P38J-8S18-HW-M

Quad Port Lightning Series Mil-Dtl-38999 Optical Transceiver,
DC to 1.0MHz / RS-485 Applications, Multimode, 850nm

ABSOLUTE MAXIMUM RATINGS

Absolute maximum limits mean that no catastrophic damage will occur if the product is subjected to these ratings for short periods, provided each limiting parameter is in isolation and all other parameters have values within the performance specification. It should not be assumed that limiting values of more than one parameter can be applied to the product at the same time.

Parameter	Symbol	Minimum	Typical	Maximum	Unit
Storage Temperature	T_s	-55		+100	°C
Supply Voltage	V_{cc}	-0.5		+4.5	V
Data Input Voltage	V_i	-0.5		V_{cc}	V

RECOMMENDED OPERATING CONDITIONS

Parameter	Symbol	Minimum	Typical	Maximum	Unit
Operating Temperature	T_A	-40		+85	°C
Supply Voltage	V_{cc}	+3.135		+3.465	V
Power Supply Noise (p-p)	N_p			200	mV
TX Input Voltage	V_i	0.8		2.0	V
RX Output Voltage (100 Ohms)	V_o	2.0			V

SPECIFICATIONS COMPLIANCE

Requirement	Feature	Condition	Notes
MIL-STD-883	ESD	Class II	2200V
MIL-STD-810	Vibration	30.0g	18mS
MIL-STD-810	Shock	40.0g	6-9mS
MIL-STD-810	Immersion	1.0 meter	2 .0Hours
MIL-STD-1344	Flame Resistance	Method 1012	30 Seconds
MIL-STD-1344	Damp Heat	10 Cycles	24 Hours
MIL-STD-38999	Mating Durability	500 Cycles	<0.5dB Change
MIL-STD 810	Salt Fog	7 Days	5 wt. %

MATERIALS

Item	Detail	Notes
Shell	Aluminum Alloy	
Shell Plating	Olive Drab Cadmium over Nickel	QQ-P-416, QQ-N-290
Insert	Thermoplastic	
Interfacial Seal	Elastomer	
Alignment Sleeves	Composite Polymer	
Printed Circuits	Polyimide / FR-4	Mil-P-31032 Type 4

Quad Port Lightning Series Mil-Dtl-38999 Optical Transceiver,
DC to 1.0MHz / RS-485 Applications, Multimode, 850nm

TRANSMITTERS T_A = Operating Temperature Range, V_{CC} = 3.135V to 3.465V

Parameter	Symbol	Minimum	Typical	Maximum	Unit
Optical Output Power ¹	P_o	-8.0		-15.0	dBm
Optical Output Wavelength	λ_{OUT}	805	850	895	nM
Optical Rise / Fall Time (10% to 90%)	$t_{R,F}$	0.6		3.0	nS
Operating Data Rate		0.0		1.0	MHz

1. BER<1x10⁻⁸ @ 1.0 Mbps @ 50% Duty Factor, tested with 62.5/125μ multimode fiber

RECEIVERS T_A = Operating Temperature Range, V_{CC} = 3.135V to 3.465V

Parameter	Symbol	Minimum	Typical	Maximum	Unit
Optical Sensitivity ¹	P_i	-26.0		-8.0	dBm
Optical Wavelength	λ_{IN}	700		900	nM
Electrical Rise / Fall Time (10% to 90%)	$t_{R,F}$			15.0	nS
Operating Data Rate		0.0		1.0	MHz

1. BER<1x10⁻⁸ @ 1.0 Mbps @ 50% Duty Factor, tested with 62.5/125μ multimode fiber

SUPPLY CURRENT T_A = Operating Temperature Range, V_{CC} = 3.135V to 3.465V

Parameter	Symbol	Minimum	Typical	Maximum	Unit
Supply Current per Port	I_{CCT}		500	650	mA

Quad Port Lightning Series Mil-Dtl-38999 Optical Transceiver,
DC to 1.0MHz / RS-485 Applications, Multimode, 850nM

OUTLINE DRAWING

Dimensions are shown as: inches (mm)

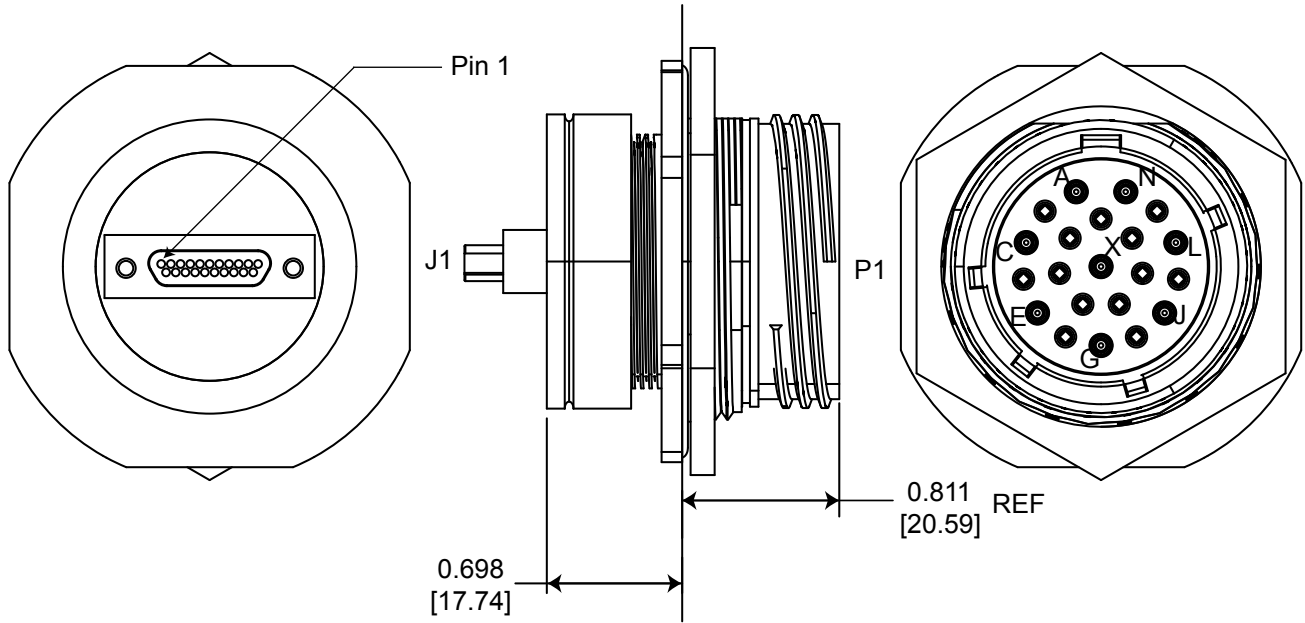

Outline Dimensions

Shell Size Code	Shell Size	J1	P1
H	23	M83513/28-C01NP Equivalent Interface	D38999/24WH21SN Equivalent Interface

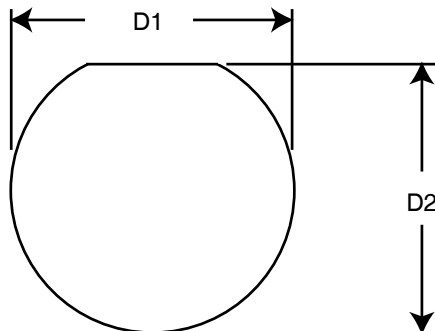

Panel Cutout Dimensions

Shell Size Code	Shell Size	D1 Min	D2 Min
H	23	1.635 (41.53)	1.585 (40.26)

Quad Port Lightning Series Mil-Dtl-38999 Optical Transceiver,
 DC to 1.0MHz / RS-485 Applications, Multimode, 850nm
OPTICAL TRANSCEIVER INSERT ARRANGEMENT

TOP
Optical Interface

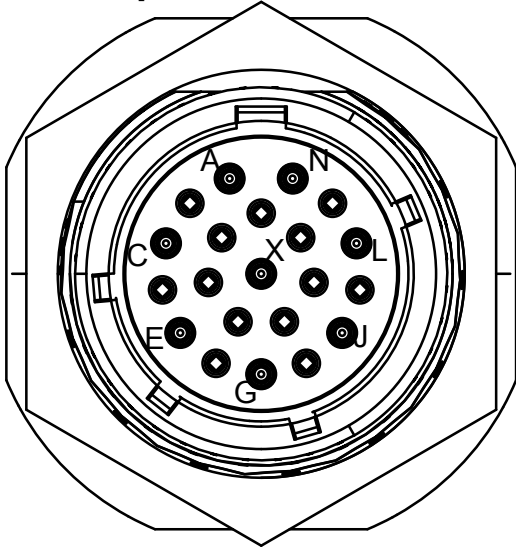

Front face of the optical transceiver insert shown, fiber optic cable plug opposite - see Appendix A2 for details

TOP
Electrical Interface

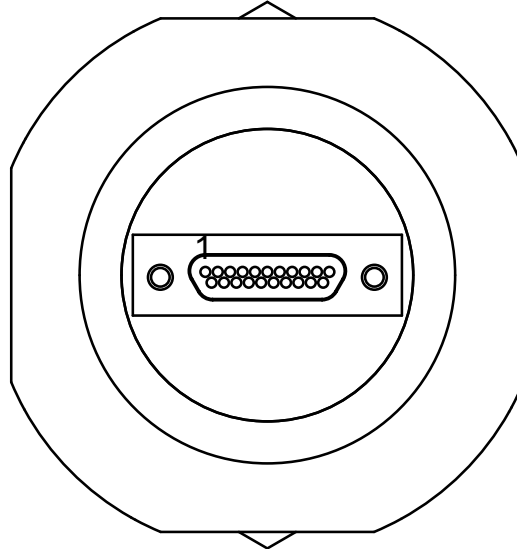

Back face of the optical transceiver insert shown - see Electrical Pin Assignment page for pin function details

OPTICAL TRANSCEIVER RECEPTACLE PORT ASSIGNMENTS

FUNCTION	OPTICAL		ELECTRICAL	
	TX	RX	TX Inputs (I, NI)	RX Outputs (I, NI)
0	N	A	4, 5	3, 2
1	L	C	8, 9	7, 6
2	J	E	14, 13	15, 16
3	G	X	18, 17	19, 20

RECEPTACLE PROTECTION CAPS

***MIL-DTL-38999/33 PROTECTION CAP PART NUMBERS**

MS RECEPTACLE CAP P/N

*See Appendix A1

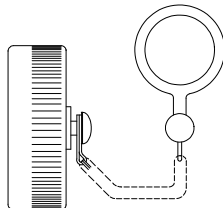

*See DSCC or SAE QPL for Approved Suppliers

Quad Port Lightning Series Mil-Dtl-38999 Optical Transceiver,
DC to 1.0MHz / RS-485 Applications, Multimode, 850nm

ELECTRICAL PIN ASSIGNMENTS

Pin	Symbol (Port)	Description	Logic Family
1	VCC	Power Supply	N/A
2	Y(0)	RX Electrical Non-Inverting Output	RS-485
3	Z(0)	RX Electrical Inverting Output	RS-485
4	B(0)	TX Electrical Inverting Input	RS-485
5	A(0)	TX Electrical Non-Inverting Input	RS-485
6	Y(1)	RX Electrical Non-Inverting Output	RS-485
7	Z(1)	RX Electrical Inverting Output	RS-485
8	B(1)	TX Electrical Inverting Input	RS-485
9	A(1)	TX Electrical Non-Inverting Input	RS-485
10	N/C	No Internal Connection	N/A
11	VCC	Power Supply	N/A
12	GND	Ground	N/A
13	A(2)	TX Electrical Non-Inverting Input	RS-485
14	B(2)	TX Electrical Inverting Input	RS-485
15	Z(2)	RX Electrical Inverting Output	RS-485
16	Y(2)	RX Electrical Non-Inverting Output	RS-485
17	A(3)	TX Electrical Non-Inverting Input	RS-485
18	B(3)	TX Electrical Inverting Input	RS-485
19	Z(3)	RX Electrical Inverting Output	RS-485
20	Y(3)	RX Electrical Non-Inverting Output	RS-485
21	GND	Ground	N/A

APPENDIX A1

RECEPTACLE PROTECTION CAPS

*MIL-DTL-38999/33 PROTECTION CAP PART NUMBERS

MS RECEPTACLE CAP P/N

*D38999/33W23N

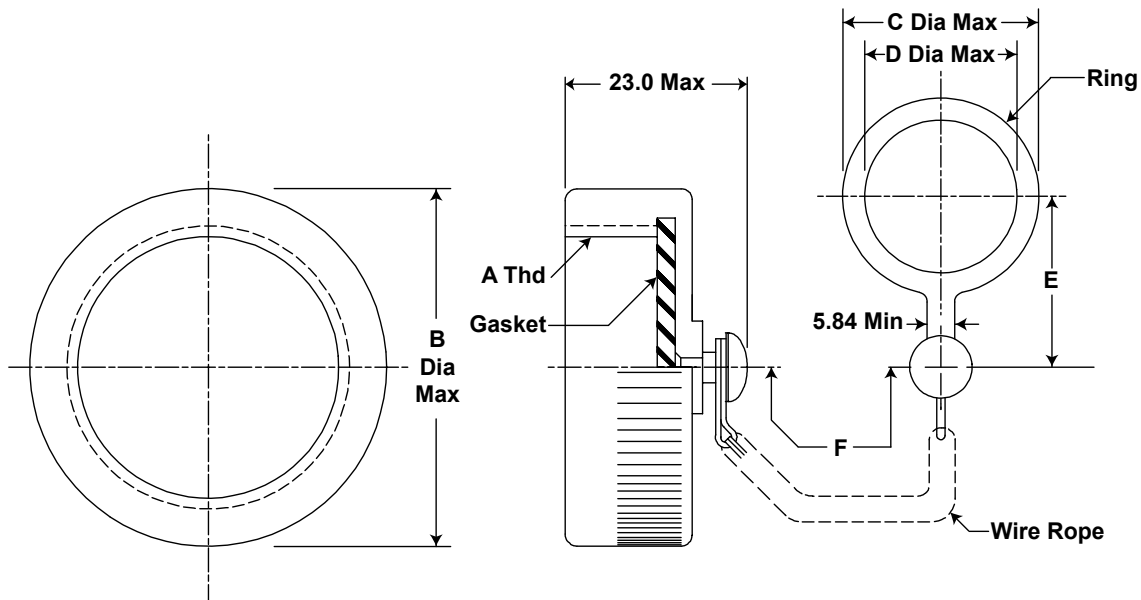

*See DSCC or SAE QPL for Approved Suppliers
<http://www.dscclia.mil/programs/qmlqpl/QPLdetail.asp?QPL=38999>

MIL-DTL-38999/33 Outline Dimensions - mm

Shell Size Code	Shell Size	A Thread (inches)	B Max Dia	C Max Dia	D Max Dia	E	F
H	23	1.5000-0.1P-0.3L-TS	45.0	54.0	42.62	37.50 31.50	+13.0 -7.0

Quad Port Lightning Series Mil-Dtl-38999 Optical Transceiver,
DC to 1.0MHz / RS-485 Applications, Multimode, 850nm

APPENDIX A2

MIL-DTL-38999 FIBER OPTIC CABLE PLUG / MIL-T-29504 PIN TERMINI

*See DSCC or SAE QPL for Approved Suppliers

<http://www.dsccl.dla.mil/programs/qmlqpl/QPLdetail.asp?QPL=38999>

*D38999 PLUG - PIN INSERT

MIL-DTL-38999 CABLE PLUG

MS PLUG P/N

*D38999/26WH21PN

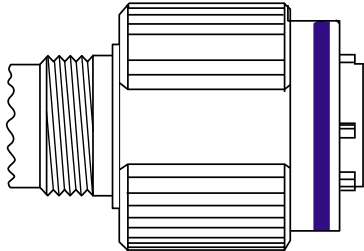

*FIBER OPTIC PIN TERMINUS

MIL-T-29504 PIN TERMINUS

MS PIN TERMINUS P/N

*M29504/04-xxxx**

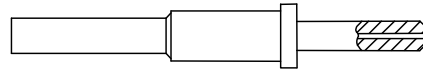

**defined by fiber optic cable configuration

*CABLE PROTECTION CAP

D38999/32 PLUG PROTECTION CAP

MS PLUG CAP P/N

*D38999/32W23N

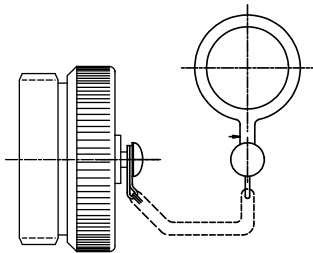

D38999 PLUG PORT FUNCTIONS

PORT NUMBER	TX	RX
0	N	A
1	L	C
2	J	E
3	G	X

TOP

Optical Cable Plug Interface

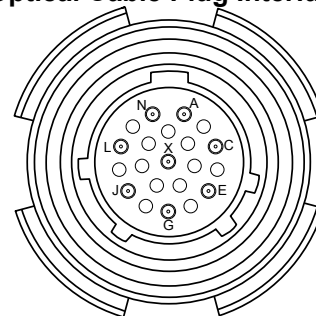

Front face of the optical cable plug pin insert shown. Transceiver insert opposite.

*CABLE BACKSHELL

MIL-C-85049 CABLE BACKSHELL

MS BACKSHELL P/N

*MS85049/xxxxxx**

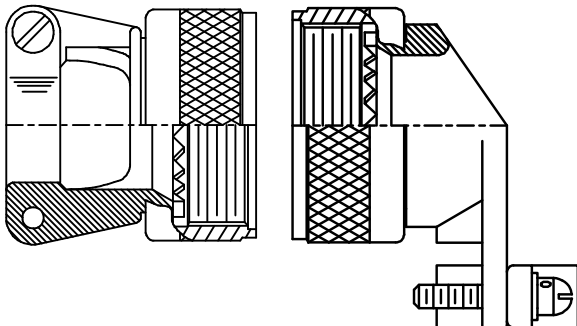

Pin Termini

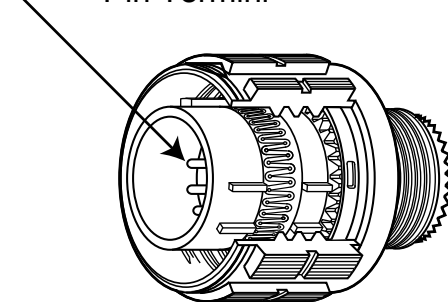

**Straight or angled backshell - defined by application / mounting configuration

Quad Port Lightning Series Mil-Dtl-38999 Optical Transceiver,
DC to 1.0MHz / RS-485 Applications, Multimode, 850nm

APPENDIX A3

Mil-Dtl-83513 Conector / Cable Assembly Guide

Cable Assembly or Flexible PCB



Optical Transceiver

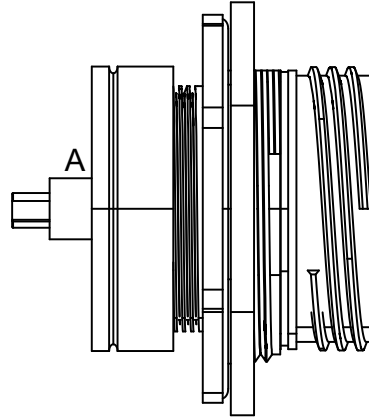

A= M83513 / 28 - CO1NW
B= M83513 / 02 - CN



192 Bob Fitz Road, Johnson City, TN 37615
salesmp@moog.com
moogprotokraft.com