



SPITFIRE SERIES

GIGABIT ETHERNET, MIL-DTL-38999, 1000BASE-T / SX MEDIA CONVERTER, MULTIMODE, 850 nM, 3.3 VDC



Spitfire series Gigabit Ethernet media converters consist of optoelectronic transmitter and receiver functions integrated along with the 1000Base-T electrical to 1000Base-SX optical media conversion circuitry into a wall mount MIL-DTL-38999 connector assembly.

The optical transmitters are high output 850 nM VCSEL lasers. The optical receivers consist of GaAs PIN and preamplifier assemblies and limiting post-amplifiers.

The electrical interface to the Spitfire series optical media converters is a ribbon coax to Samtec EQCD high density cable assembly enabling SMT interconnection to a customer's backplane, motherboard or daughtercard.

Spitfire series Gigabit Ethernet media converters are vibration isolated, environmentally hardened components designed for use in harsh environment applications.

- External interface sealed against liquid or solid contaminants
- Shock and vibration resistant

QUAD PORT SPITFIRE SERIES MIL-DTL-38999, 1000BASE-T TO 1000BASE-SX MEDIA CONVERTER, MULTIMODE, 3.3 VDC, 850 NM

Single Port, Size 15 Receptacles
MIL-DTL-38999 Optical to Samtec SMT Electrical

FEATURES

- Compliant with IEEE-802.3:2005 Gigabit Ethernet 1000Base-SX and 1000Base-T
- Optical fiber link distances up to 550 meters (50 / 125 μ M)
- Operating temperature range from -40° to +85° C
- Shock, vibration and immersion resistant per MIL-STD-810
- Olive drab cadmium plating meets stringent EMI / RFI and corrosion resistance performance specifications
- Aluminum housings are strong, durable and light weight
- MIL-T-29504 compliant optical fiber connector interface
- MIL-DTL-38999 fiber optic insert per MIL-STD-1560
- Samtec EQCD series electrical connector for SMT interface

APPLICATIONS

Spitfire series bulkhead mounted Gigabit Ethernet media converters enable high speed network communications over long distances in harsh environments.

- Gigabit Ethernet switches and peripherals
- Telecom and datacom switch / router rack-to-rack links
- Storage or computation clusters

The MIL-DTL-38999, series III shell provides a sealed optical interface that is water-tight to MIL-STD-810 when mated.

The multimode optical fiber interface supports applications where copper cable link distance, bandwidth, weight or bulk make the use of twisted pair, twinax or quadrax copper conductors unacceptable.

ORDERING INFORMATION

Application	Part Number
1000Base-T to SX, Flange	P38F-8S1T-HW-Lxxx
1000Base-T to SX, Jam Nut	P38J-8S1T-HW-Lxxx

See page 7 for standard part number / cable length options.

QUAD PORT SPITFIRE SERIES MIL-DTL-38999, 1000BASE-T TO 1000BASE-SX MEDIA CONVERTER, MULTIMODE, 3.3 VDC, 850 NM

ABSOLUTE MAXIMUM RATINGS

Absolute maximum limits mean that no catastrophic damage will occur if the product is subjected to these ratings for short periods, provided each limiting parameter is in isolation and all other parameters have values within the performance specification. It should not be assumed that limiting values of more than one parameter can be applied to the product at the same time.

Parameter	Symbol	Minimum	Typical	Maximum	Unit
Storage Temperature	T_s	-55		+100	°C
Supply Voltage	V_{cc}	-0.5		+4.5	V
Data Input Voltage	V_i	-0.5		V_{cc}	V

RECOMMENDED OPERATING CONDITIONS

Parameter	Symbol	Minimum	Typical	Maximum	Unit
Operating Temperature	T_A	-40		+85	°C
Supply Voltage	V_{cc}	+3.135	3.3	+3.465	V
Power Supply Noise (p-p)	N_p			200	mV

CONNECTOR INTERFACE SPECIFICATIONS COMPLIANCE

Requirement	Feature	Condition	Notes
MIL-STD-883	ESD	Class II	2200 V
MIL-STD-810	Vibration	3.8 g ² / Hz	43 G rms
MIL-STD-810	Shock	40.0 g	6-9 mS
MIL-STD-810	Immersion	1.0 Meter	2.0 Hours
MIL-STD-1344	Flame Resistance	Method 1012	30 Seconds
MIL-STD-1344	Damp Heat	10 Cycles	24 Hours
MIL-STD-38999	Mating Durability	500 Cycles	< 0.5 dB Change
FDA / CDRH / IEC-825-1	Eye Safety	Class 1	No Safety Interlocks Required

MATERIALS

Item	Detail	Notes
D38999 Cylindrical Shells	Aluminum Alloy	
D38999 Cylindrical Shell Platings	Olive Drab Cadmium, Electroless Nickel or Zinc Nickel	
Inserts	Thermoplastic	
Interfacial Seals	Elastomer	
Alignment Sleeves	Thermoplastic	
Printed Circuits	Polyimide / FR-4	
Backshell	Aluminum Alloy	

QUAD PORT SPITFIRE SERIES MIL-DTL-38999, 1000BASE-T TO 1000BASE-SX MEDIA CONVERTER, MULTIMODE, 3.3 VDC, 850 NM

OPTICAL TRANSMITTERS T_A = OPERATING TEMPERATURE RANGE, V_{CC} = 3.135 V TO 3.465 V

Parameter	Symbol	Minimum	Typical	Maximum	Unit
Optical Output Power	P_O	-9.5		-4.0	dBm
Optical Output Wavelength	λ_{OUT}	830	850	860	nM
Spectral Width	$\Delta\lambda_{RMS}$			0.85	nM

OPTICAL RECEIVERS T_A = OPERATING TEMPERATURE RANGE, V_{CC} = 3.135 V TO 3.465 V

Parameter	Symbol	Minimum	Typical	Maximum	Unit
Optical Sensitivity	P_I	-19.0		-2.0	dBm
Optical Wavelength	λ_{IN}	830	850	860	nM

POWER SUPPLY CURRENT T_A = OPERATING TEMPERATURE RANGE, V_{CC} = 3.135 V TO 3.465 V

Parameter	Symbol	Minimum	Typical	Maximum	Unit
Supply Current Per Port	I_{CCT}		450	600	mA

OPTICAL LINK DISTANCES

Protocol	Cable Specification	Distance
Gigabit Ethernet - IEEE-802.3:2005 - 1000BASE-SX	62.5 / 125 μ 200 MHz*Km	275 M
	50 / 125 μ 500 MHz*Km	550 M

QUAD PORT SPITFIRE SERIES MIL-DTL-38999, 1000BASE-T TO 1000BASE-SX MEDIA CONVERTER, MULTIMODE, 3.3 VDC, 850 NM

OUTLINE DRAWING - FLANGE OPTION

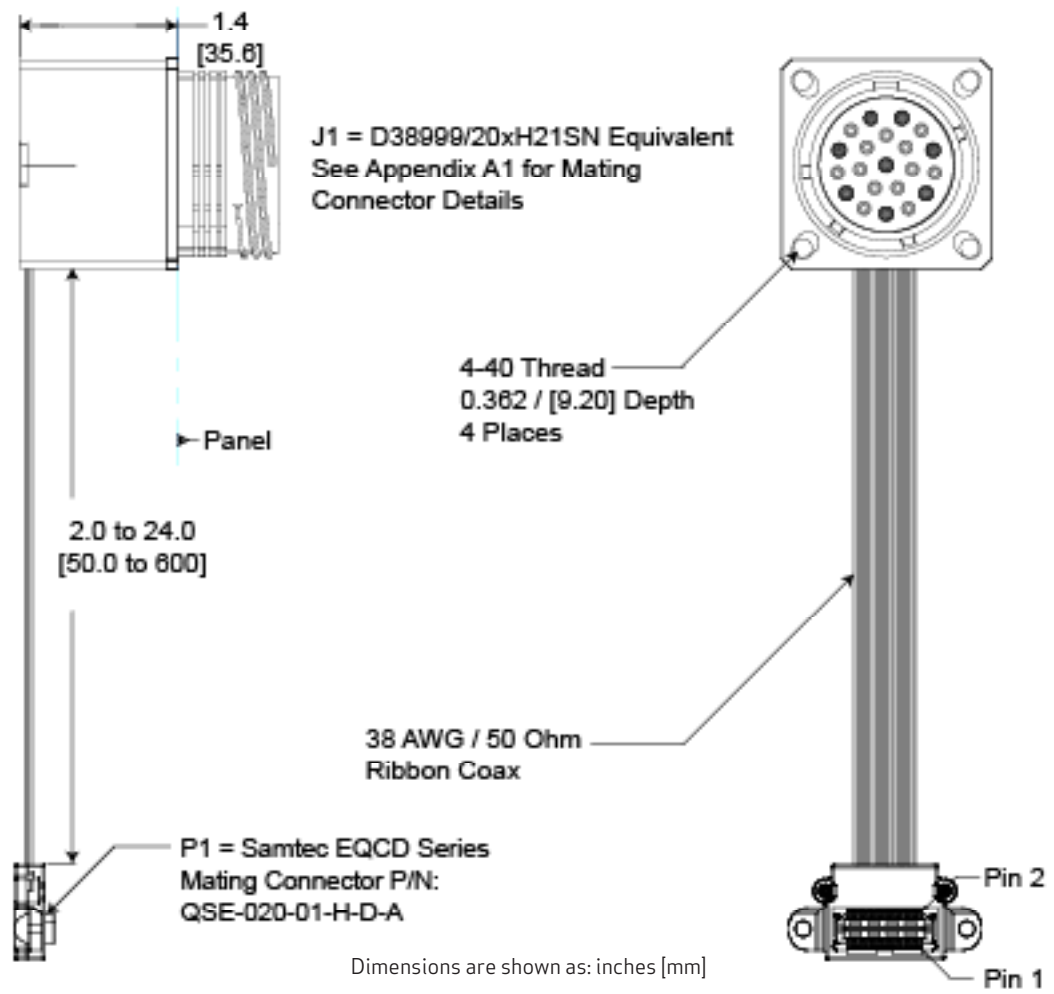

PANEL CUTOUT DIMENSIONS REAR PANEL MOUNTING ONLY

Shell Size Code	Shell Size	M Min.	P Holes	R Bsc.
H	23	1.547 [39.29]	0.159 [4.0] 0.149 [3.8]	1.375 [34.9]

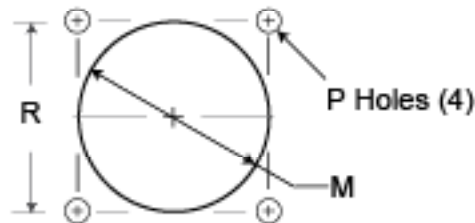

Part Number = *P38F-8xxx-Hx-Lxxx

*See page 7 for part number / cable length options and page 12 for complete ordering options.

QUAD PORT SPITFIRE SERIES MIL-DTL-38999, 1000BASE-T TO 1000BASE-SX MEDIA CONVERTER, MULTIMODE, 3.3 VDC, 850 NM

OUTLINE DRAWING - JAM NUT OPTION

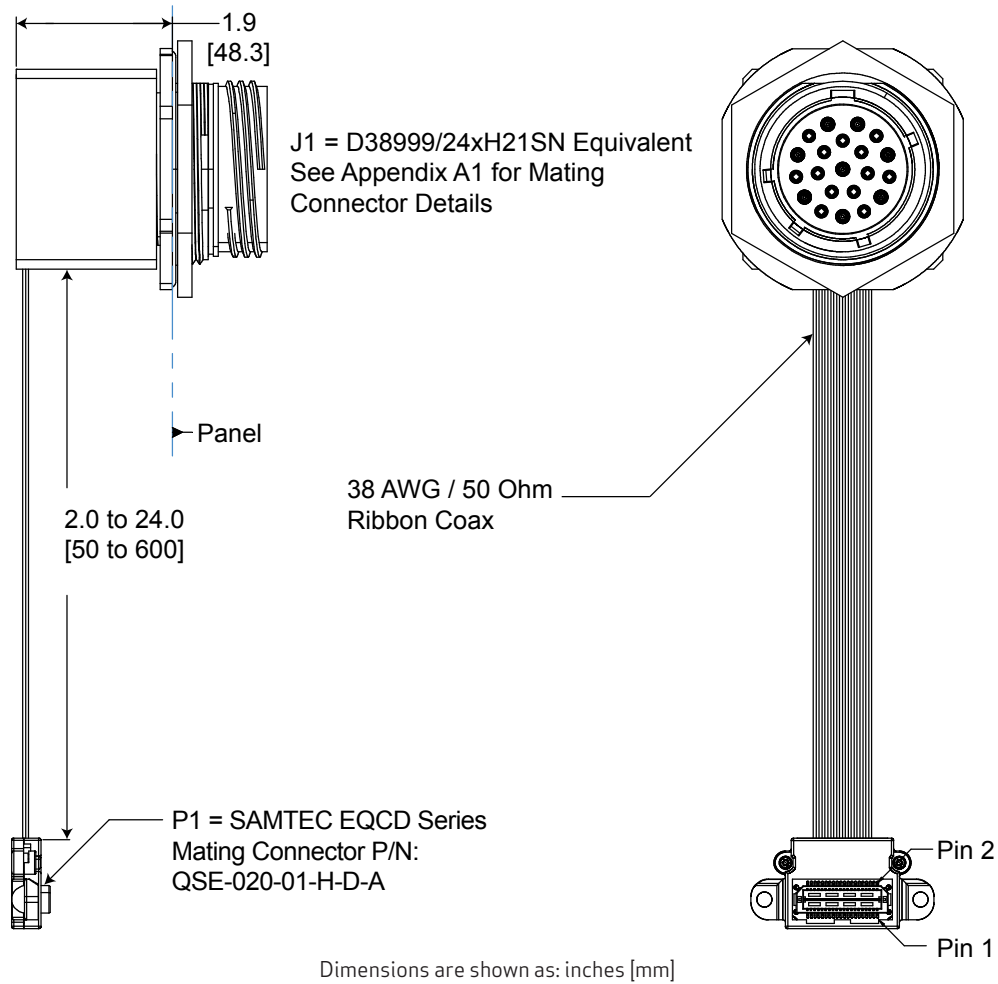

PANEL CUTOUT DIMENSIONS

Shell Size Code	Shell Size	D1 Min.	D2 Min.
H	23	1.635 [41.53]	1.585 [40.26]

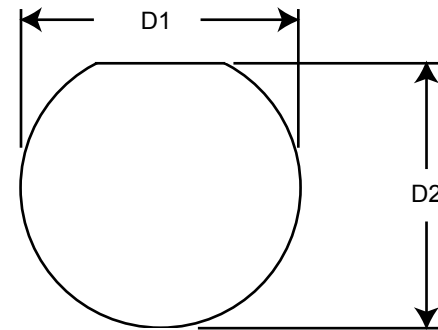

Part Number = *P38J-2xxx-Dx-Lxxx

*See page 7 for part number / cable length options and page 12 for complete ordering options.

QUAD PORT SPITFIRE SERIES MIL-DTL-38999, 1000BASE-T TO 1000BASE-SX MEDIA CONVERTER, MULTIMODE, 3.3 VDC, 850 NM

OUTLINE DRAWING CABLE LENGTH OPTIONS

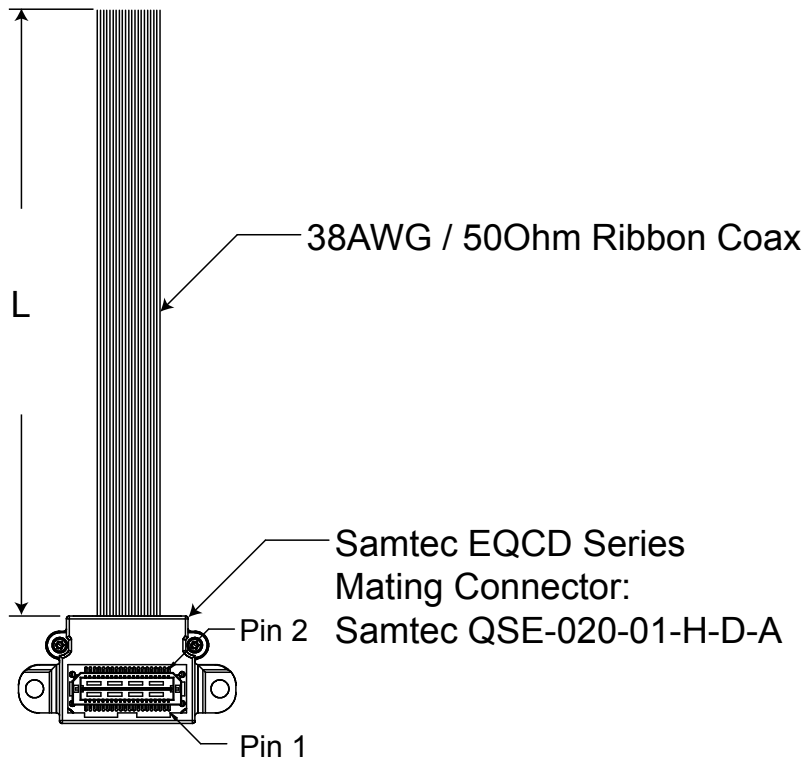

RIBBON COAX CABLE LENGTH OPTIONS

L (mm) ± 6.0	Item #
50	xxxx-xxxx-xx-L050
100	xxxx-xxxx-xx-L100
150	xxxx-xxxx-xx-L150
200	xxxx-xxxx-xx-L200
250	xxxx-xxxx-xx-L250

QUAD PORT SPITFIRE SERIES MIL-DTL-38999, 1000BASE-T TO 1000BASE-SX MEDIA CONVERTER, MULTIMODE, 3.3 VDC, 850 NM

J1 D38999 PIN AND PORT ASSIGNMENTS

TOP
Optical Interface

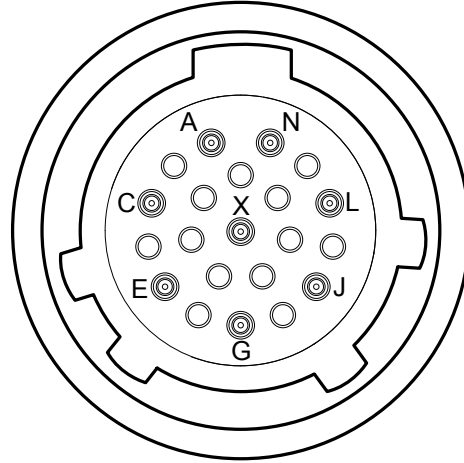

Front view of the 38999 optical insert shown, fiber optic cable plug opposite - see Appendix A1 for details.

MIL-DTL-38999 OPTICAL INTERFACE

Port Number	TX	RX
0	J	L
1	N	G
2	X	A
3	E	C

QUAD PORT SPITFIRE SERIES MIL-DTL-38999, 1000BASE-T TO 1000BASE-SX MEDIA CONVERTER, MULTIMODE, 3.3 VDC, 850 NM

PRINTED CIRCUIT BOARD FOOTPRINT

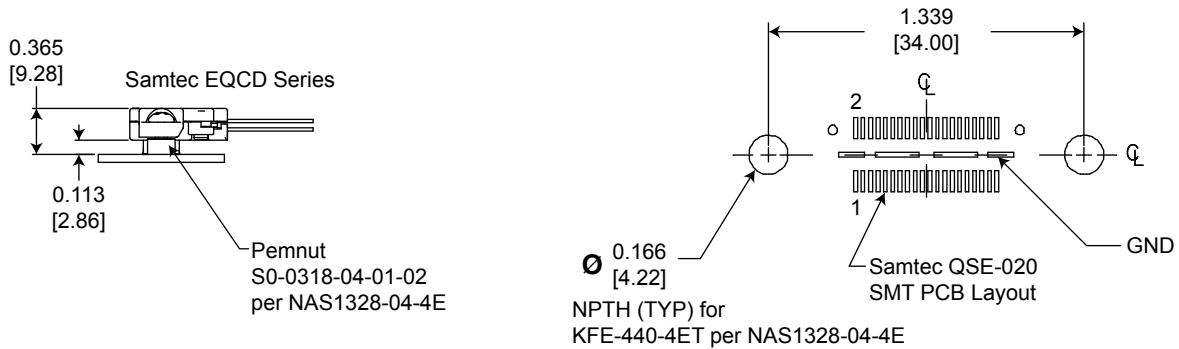

Dimensions are shown as: inches [mm]

SAMTEC EQCD PIN ASSIGNMENTS - CONTINUED ON THE NEXT PAGE

Pin Number	Port Number	Function	Input / Output	RJ-45 EQ Pin Number	Logic Family
1	0	MDA+	Input / Output	1	IEEE-802.3:2005 1000Base-T
2	1	MDA+	Input / Output	1	IEEE-802.3:2005 1000Base-T
3	0	MDA-	Input / Output	2	IEEE-802.3:2005 1000Base-T
4	1	MDA-	Input / Output	2	IEEE-802.3:2005 1000Base-T
5	0	MDB+	Input / Output	3	IEEE-802.3:2005 1000Base-T
6	1	MDB+	Input / Output	3	IEEE-802.3:2005 1000Base-T
7	0	MDB-	Input / Output	6	IEEE-802.3:2005 1000Base-T
8	1	MDB-	Input / Output	6	IEEE-802.3:2005 1000Base-T
9	0	MDC+	Input / Output	4	IEEE-802.3:2005 1000Base-T
10	1	MDC+	Input / Output	4	IEEE-802.3:2005 1000Base-T
11	0	MDC-	Input / Output	5	IEEE-802.3:2005 1000Base-T
12	1	MDC-	Input / Output	5	IEEE-802.3:2005 1000Base-T
13	0	MDD+	Input / Output	7	IEEE-802.3:2005 1000Base-T
14	1	MDD+	Input / Output	7	IEEE-802.3:2005 1000Base-T
15	0	MDD-	Input / Output	8	IEEE-802.3:2005 1000Base-T
16	1	MDD-	Input / Output	8	IEEE-802.3:2005 1000Base-T
17	0	*Reset_Low	Input	N/A	LVTTTL with Internal Pull-up
18	1	*Reset_Low	Input	N/A	LVTTTL with Internal Pull-up
19	0-3	V _{CC}	Input	N/A	3.135 to 3.465 VDC
20	0-3	V _{CC}	Input	N/A	3.135 to 3.465 VDC

*Reset function: Logic "0" Input = restart, registers initialized; Logic "1", Open or High Z Input = normal operation, center slug is isolated GND.

QUAD PORT SPITFIRE SERIES MIL-DTL-38999, 1000BASE-T TO 1000BASE-SX MEDIA CONVERTER, MULTIMODE, 3.3 VDC, 850 NM

PRINTED CIRCUIT BOARD FOOTPRINT

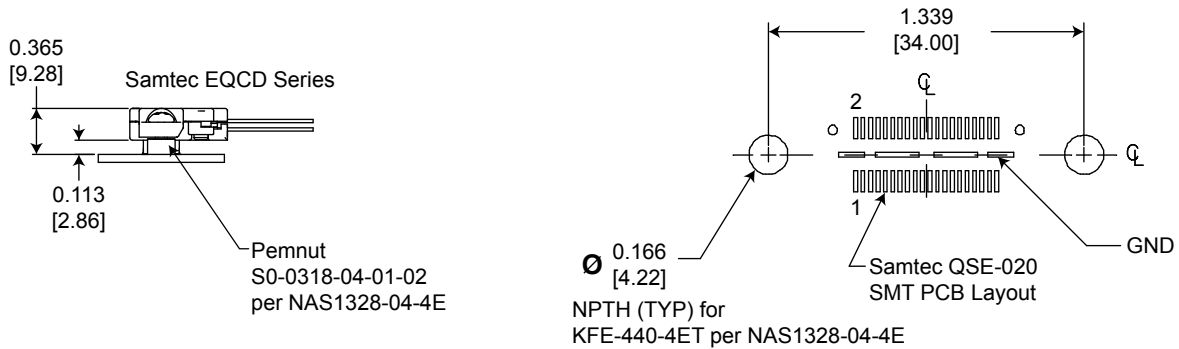

Dimensions are shown as: inches [mm]

SAMTEC EQCD PIN ASSIGNMENTS - CONTINUED FROM PREVIOUS PAGE

Pin Number	Port Number	Function	Input / Output	RJ-45 EQ Pin Number	Logic Family
21	0-3	V _{CC}	Input	N/A	3.135 to 3.465VDC
22	0-3	V _{CC}	Input	N/A	3.135 to 3.465VDC
23	2	*Reset_Low	Input	N/A	LVTTTL with Internal Pullup
24	3	*Reset_Low	Input	N/A	LVTTTL with Internal Pullup
25	2	MDA+	Input / Output	1	IEEE-802.3:2005 1000Base-T
26	3	MDA+	Input / Output	1	IEEE-802.3:2005 1000Base-T
27	2	MDA-	Input / Output	2	IEEE-802.3:2005 1000Base-T
28	3	MDA-	Input / Output	2	IEEE-802.3:2005 1000Base-T
29	2	MDB+	Input / Output	3	IEEE-802.3:2005 1000Base-T
30	3	MDB+	Input / Output	3	IEEE-802.3:2005 1000Base-T
31	2	MDB-	Input / Output	6	IEEE-802.3:2005 1000Base-T
32	3	MDB-	Input / Output	6	IEEE-802.3:2005 1000Base-T
33	2	MDC+	Input / Output	4	IEEE-802.3:2005 1000Base-T
34	3	MDC+	Input / Output	4	IEEE-802.3:2005 1000Base-T
35	2	MDC-	Input / Output	5	IEEE-802.3:2005 1000Base-T
36	3	MDC-	Input / Output	5	IEEE-802.3:2005 1000Base-T
37	2	MDD+	Input / Output	7	IEEE-802.3:2005 1000Base-T
38	3	MDD+	Input / Output	7	IEEE-802.3:2005 1000Base-T
39	2	MDD-	Input / Output	8	IEEE-802.3:2005 1000Base-T
40	3	MDD-	Input / Output	8	IEEE-802.3:2005 1000Base-T

*Reset function: Logic "0" Input = restart, registers initialized; Logic "1", Open or High Z Input = normal operation, all other pins are N/C, center slug is isolated GND.

QUAD PORT SPITFIRE SERIES MIL-DTL-38999, 1000BASE-T TO 1000BASE-SX MEDIA CONVERTER, MULTIMODE, 3.3 VDC, 850 NM

APPLICATION SCHEMATIC

FOR QUAD PORT 1000BASE-T TO 1000BASE-SX MEDIA CONVERTER APPLICATIONS

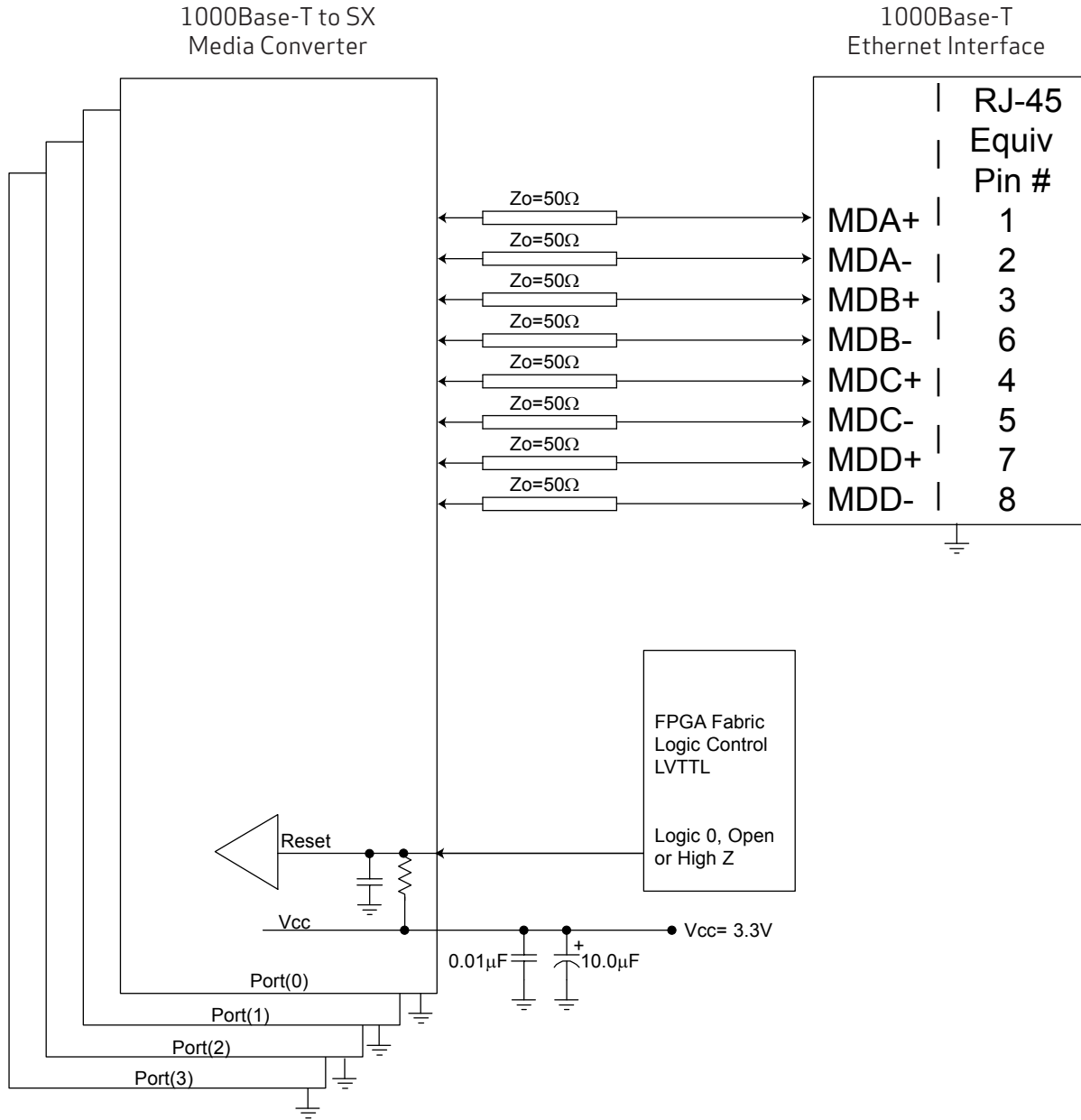

All Protokraft statements, technical information and recommendations related to the products herein are based upon information believed to be reliable or accurate. However, the accuracy or completeness thereof is not guaranteed, and Protokraft assumes no responsibility for any inaccuracies. The user assumes all risks and liability whatsoever in connection with the use of a product or its application. Protokraft reserves the right to change at any time, without prior or subsequent notice, the design, specifications, function, fit or form of its products described herein, including withdrawal at any time of a product offered for sale herein. Protokraft makes no representations that the products herein are free from any intellectual property claims of others. Protokraft and the Protokraft logo are trademarks of Protokraft, LLC. Other trademarks are the property of their respective holders. Contact Protokraft for prices and availability. For the most recent version of this data sheet, please go to the Protokraft website at <http://www.protokraft.com>. In case of discrepancy, the web version takes precedence over any printed literature.

QUAD PORT SPITFIRE SERIES MIL-DTL-38999, 1000BASE-T TO 1000BASE-SX MEDIA CONVERTER, MULTIMODE, 3.3 VDC, 850 NM

APPENDIX A1 MIL-DTL-38999 FIBER OPTIC CABLE PLUG / MIL-T-29504 PIN TERMINI

*See DSCC or SAE QPL for Approved Suppliers
<http://www.dsccl.dla.mil/programs/qmlqpl/QPLdetail.asp?QPL=38999>

*D38999 PLUG - PIN INSERT MIL-DTL-38999 CABLE PLUG

MS Plug P/N *D38999 / 26WH21PN

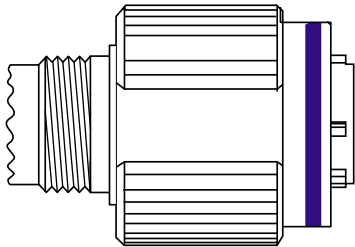

*CABLE PROTECTION CAP D38999 / 32 PLUG PROTECTION CAP

MS Plug Cap P/N *D38999 / 32W23N

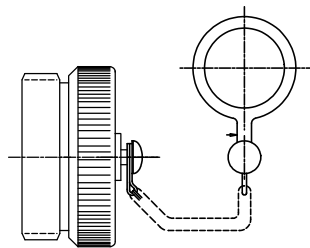

*CABLE BACKSHELL MIL-C-85049 CABLE BACKSHELL

MS Backshell P/N *MS85049 / XXXXXX**

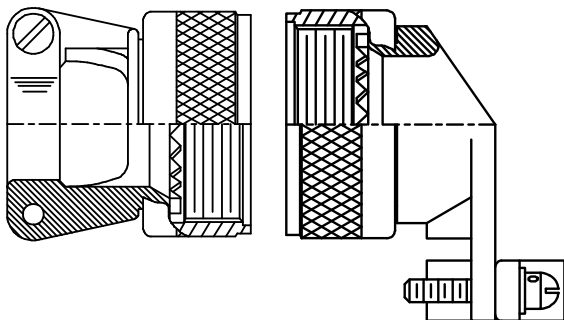

**Straight or angled backshell - defined by application / mounting configuration

*FIBER OPTIC PIN TERMINUS MIL-T-29504 PIN TERMINUS

MS Pin Terminus P/N *M29504 / 04-xxxx**

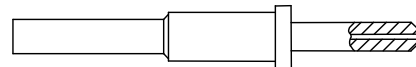

**Defined by fiber optic cable configuration

D38999 PLUG PORT FUNCTIONS

Port Number	TX	RX
0	J	L
1	N	G
2	X	A
3	E	C

TOP
Optical Cable Plug Interface

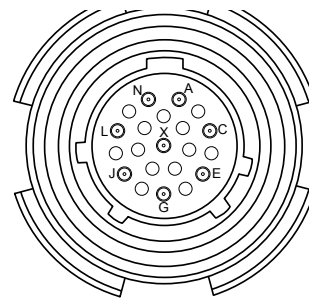

Front face of the optical cable plug pin insert shown. Transceiver insert opposite.

Pin Termini

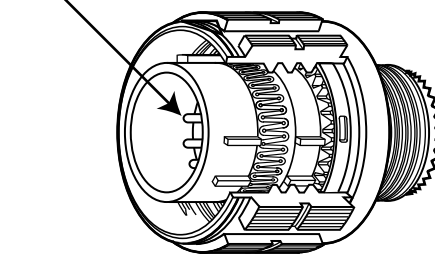

QUAD PORT SPITFIRE SERIES MIL-DTL-38999, 1000BASE-T TO 1000BASE-SX MEDIA CONVERTER, MULTIMODE, 3.3 VDC, 850 NM

APPENDIX A2 PART NUMBER OPTIONS

SINGLE PORT, FAST ETHERNET

P38 **x** - **8** **S** **1** **T** - **H** **x** **x** - **L**

SHELL CONFIGURATION
P38 = 38999 Receptacle

SHELL CONFIGURATION
F = Square Flange
J = Jame Nut

CHANNELS (TX + RX)
8 = 4 TX + 4 RX

WAVELENGTH
S = 850 nM

CABLE MODE
1 = Multimode

FIBER OPTIC INTERFACE
T = 1.25 Mbps

SHELL SIZE CODE
H = 23-21

SHELL PLATING
F = NI
W = OD CD / NI
Z = ZN / NI

SHELL POLARIZATION
 (Leave blank) = N
A = A
B = B
C = C
D = D

ELECTRICAL INTERFACE
L = Ribbon Coax to Samtec EQCD Series - Cable Length TBD

Other wavelength, mounting and port count options are available.
 Please consult the Protokraft website for alternate configurations.



192 Bob Fitz Road, Johnson City, TN 37615
 salesmp@moog.com
 moogprotokraft.com